

LOC	DIST	P	F	ZONE	LTR	DESCRIPTION	DATE	APPD
AD	25							
				B		REDRAWN PER AD-5103	3/91	MB
				C		REVISED PER AD6120	4/28/92	MB
				D		REVISED PER 0010-1146-94	7/29/94	SG
				E		REVISED PER 0010-0072-96	5/16/96	RB MB
				F		REV PER EC 0512-0047-02	12/10/02	RG MP

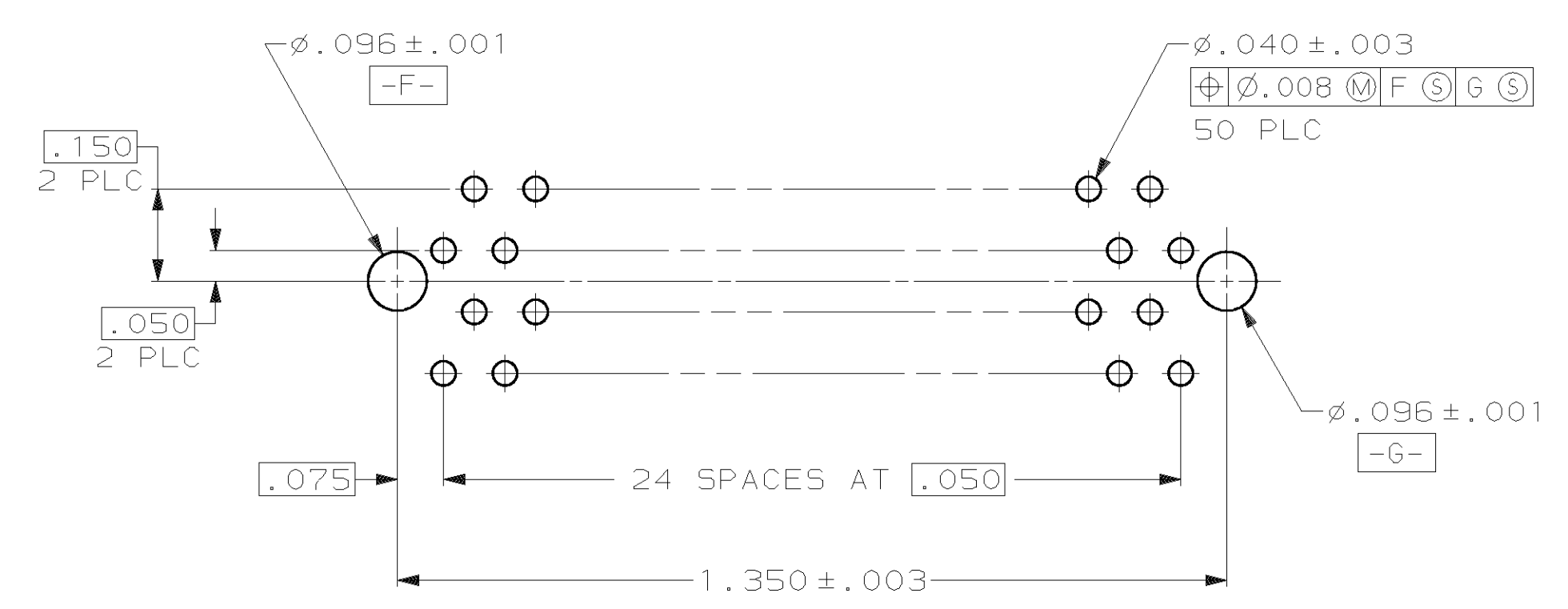

RECOMMENDED CONNECTOR MOUNTING HOLE PATTERN
 (CONNECTOR SIDE SHOWN)

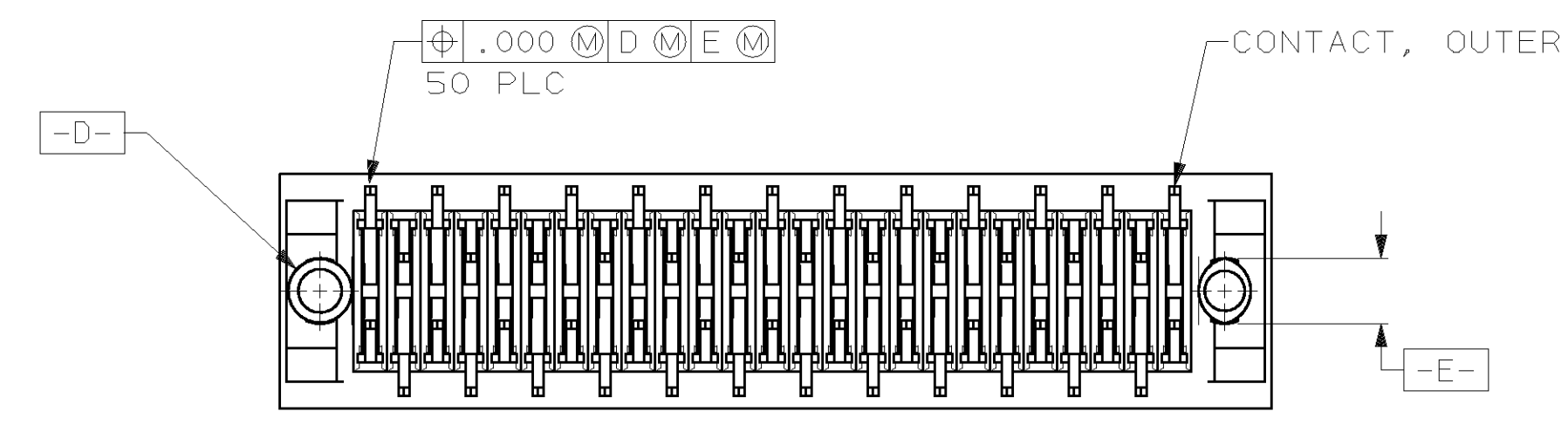
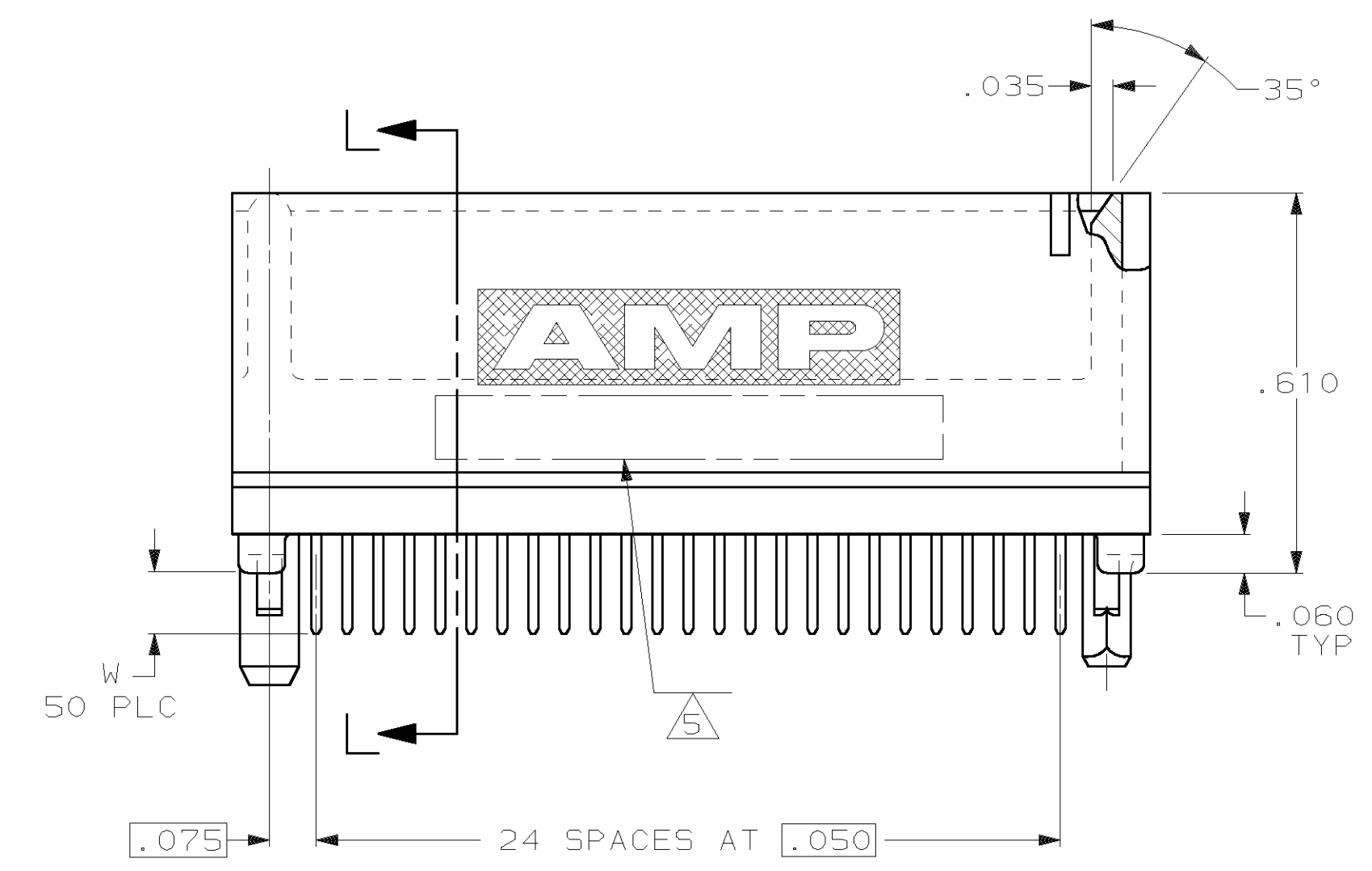
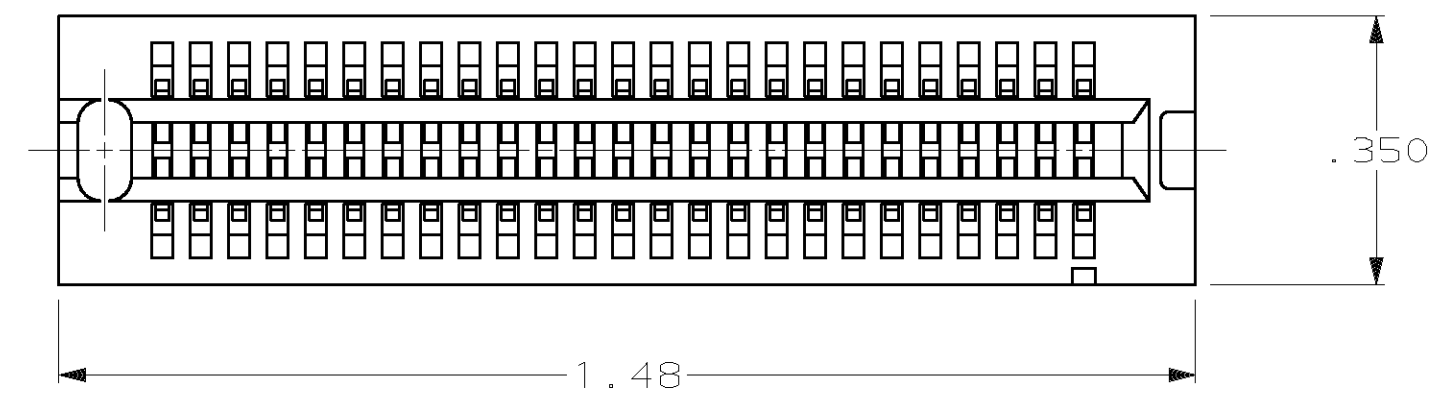
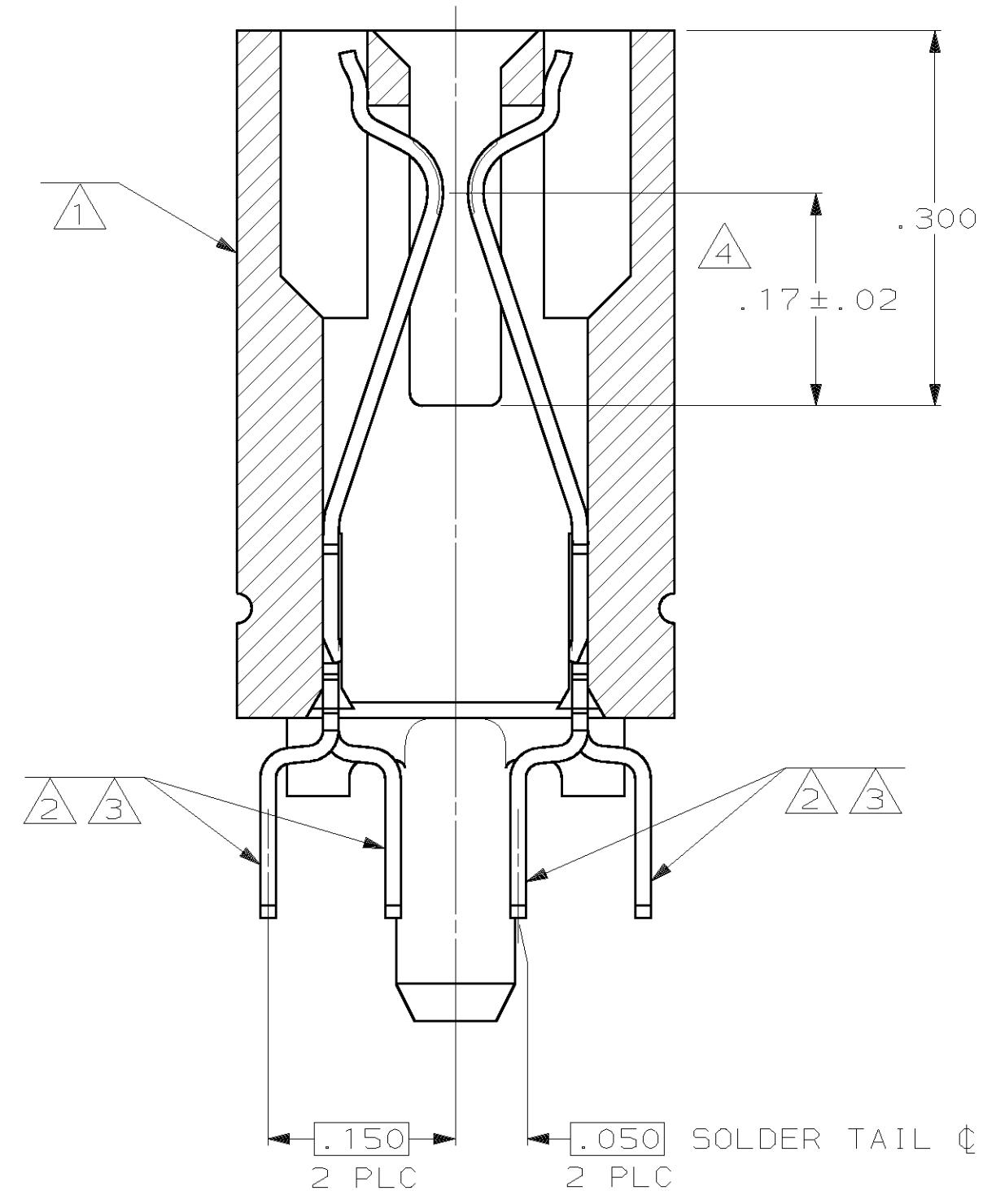

SECTION L-L
 SCALE 8:1

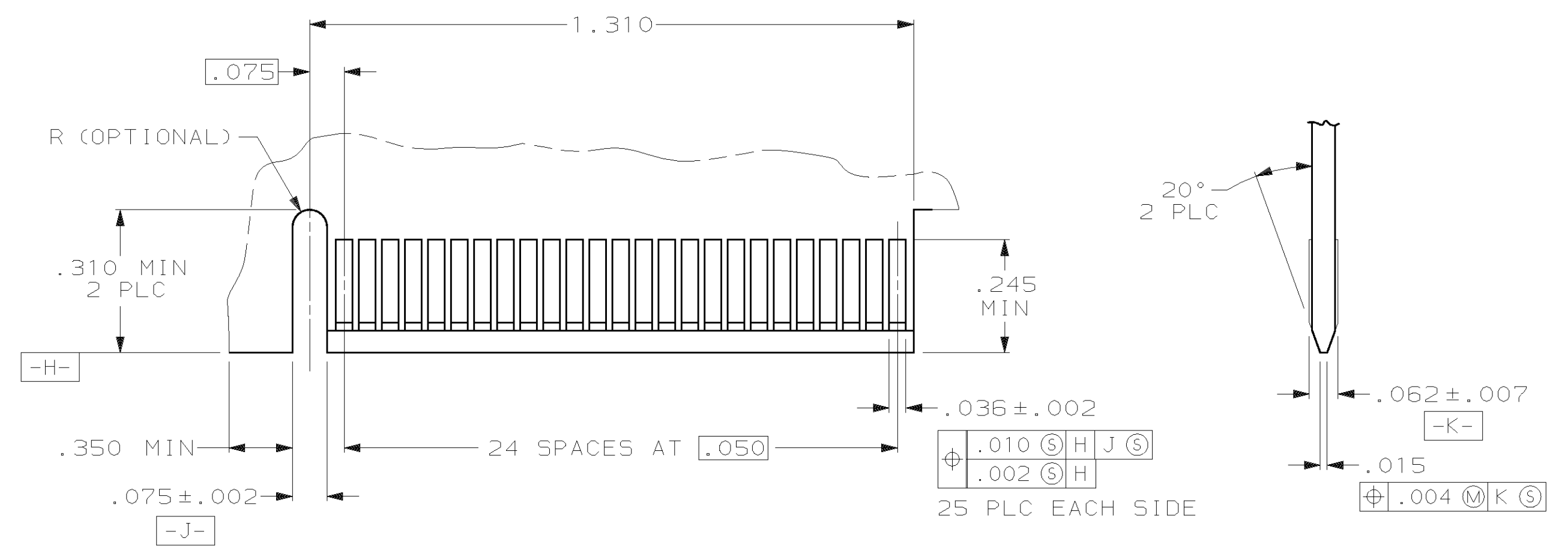

RECOMMENDED MATING BOARD EDGE CONFIGURATION

- 1 HOUSING: HIGH TEMPERATURE THERMOPLASTIC. COLOR: BROWN.
- 2 CONTACT: PHOSPHOR BRONZE.
- 3 CONTACT FINISH: .000100 MIN NICKEL ALL OVER.
.000030 MIN GOLD OVER NICKEL IN CONTACT AREA.
.000100 MIN TIN-LEAD OVER NICKEL ON SOLDER TAILS.
- 4 DISTANCE FROM CONTACT POINT TO BOTTOM OF CARD SLOT.
- 5 AMP PART NUMBER, DATE CODE AND CSA LOGO MARKED IN APPROXIMATE AREA SHOWN.

.14	650719-2
.10	650719-1
W	PART NUMBER

DO NOT SCALE PRINT. UNLESS SPECIFIED DIMENSIONS IN mm [INCHES] TOLERANCES ON: 2 PLC DEC ± .01 3 PLC DEC ± .005 ANGLES ± 2°		DR 3/21/91 K.L.CLOUSER/UTA		AMP Incorporated Harrisburg, PA 17105-3608	
MATERIAL HOUSING: 1 CONTACT: 2		CHK 11-21-91 M.BOWERS			
FINISH CONTACT: 3		APPD 11-21-91 M.THURMA		NAME CONNECTOR ASSEMBLY, END KEYED, 25 DUAL POSITION, .050 SERIES, STANDARD EDGE	
MATERIAL		APPD 11-21-91 M.BOWERS		SIZE D 00779	
PRODUCT SPEC 108-14034		APPLICATION SPEC 114-26012		CAGE CODE 00779	
WEIGHT		SCALE 4:1		DRAWING NO 650719	
				SHEET 1 OF 1	